

## ASSEMBLY SPM BUSH FITTING

### Case Study-1

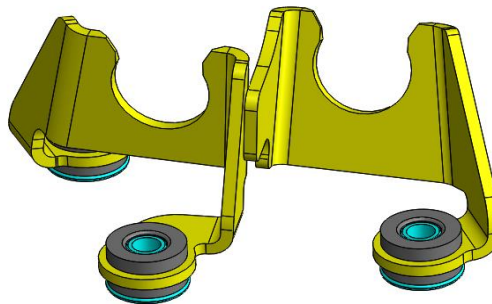

#### The Problem



- Customer's problem-
- Manpower (10 nos)
  - Productivity

#### Solution



Automatic Assembly SPM  
With Bowl feeder and  
SCARA Robot for Pick &  
place.

#### Benefits



- Manpower reduces to 2 nos.
- Productivity increases.

## Component Description

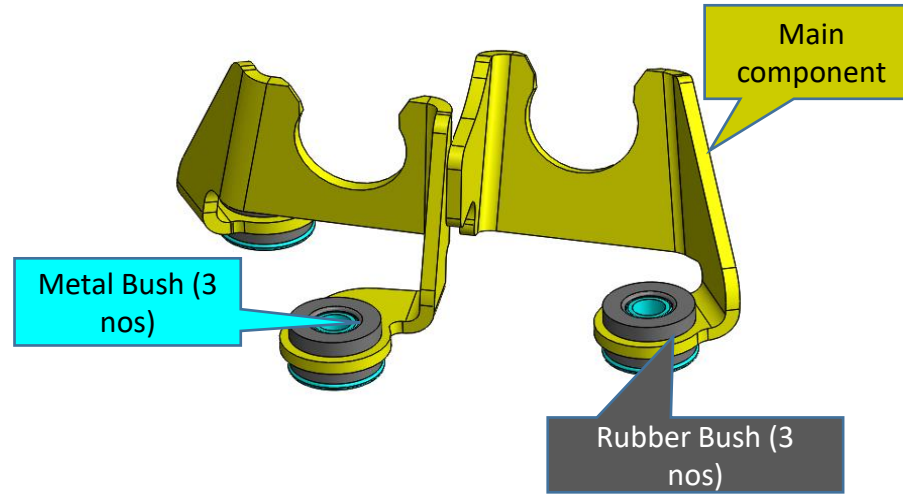

## BUSH FITTING SPM

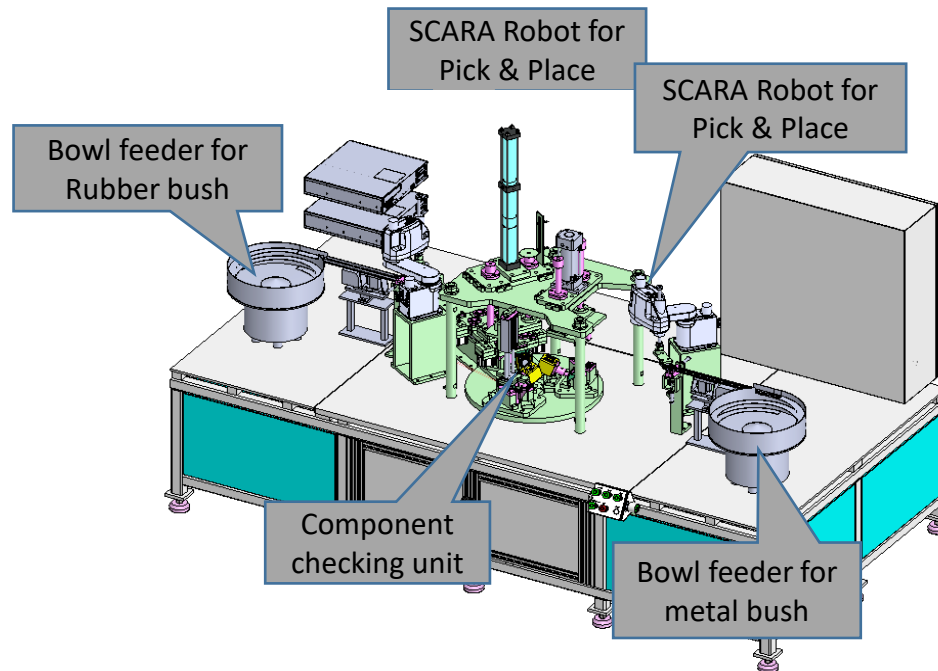

# OPERATION SEQUENCE



## Before Automation

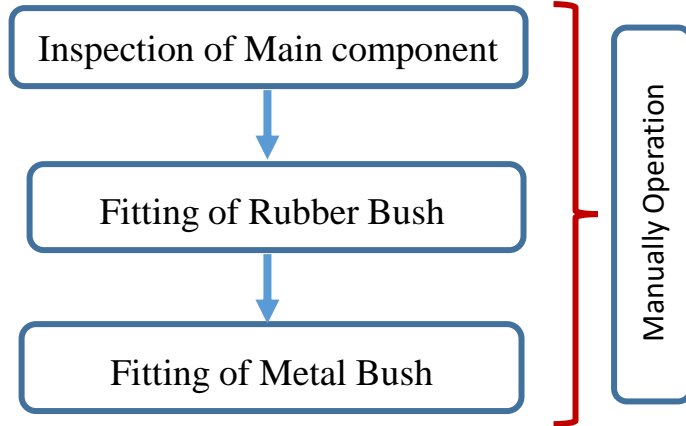

❖ **Manpower consumes 10 nos to meet the volume of 2200 / Day**

## After Automation

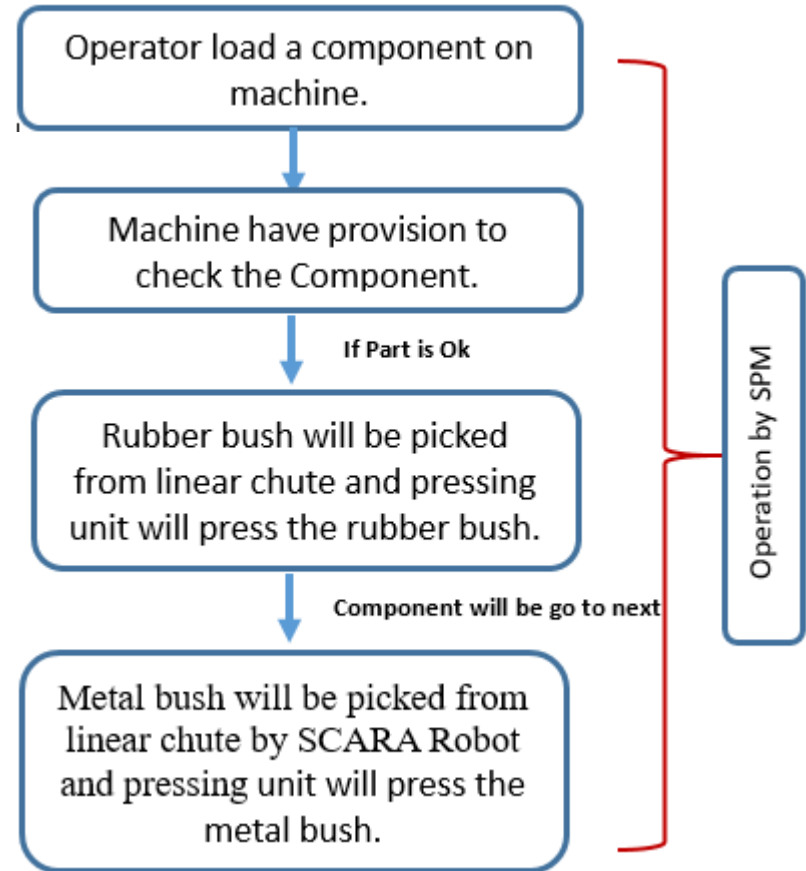

❖ **Manpower consumes 2 nos to meet the volume of 2200 / Day**

## SAVINGS and BENEFITS :



Description	UOM	Parameters
Number of Shift / Day	Numbers	2
Man power Saving /Day	Numbers	8
Manpower Rate/Day	Rupees	577
Saving/Day	Rupees	4616
Workings Days/Year	Days	302
Saving Per Year	Rupees	1394032